

THE RIGHT VACUUM



INDUSTRIAL VACUUM CLEANERS

High filtering efficiency: a hygienic star filter with a large surface area ensures the maximum vacuuming efficiency for long periods of time when vacuuming very fine dust.

Effective filter cleaning by means of an ergonomic manual shaker.

Upstream & downstream absolute filtration (HEPA), grill and valve for bin liquids draining, swarf basket, vacuum balance system for direct dust collection into disposal plastic bag are available as **options**.

User friendly: equipped with a robust frame, large diameter wheels and an easily releasable dust collection bin with wheels.

High capacity bin (25, 50, 90, 120 or 175 liters) with quick and innovative release system ensure easy vacuumed material emptying.

Compact, very stable and easy to handle.

Versatile: suitable for vacuuming fine dust, swarf, coolants, oil and water residue.

Design: balanced and elegant.



Large surface area star filter



Ergonomic and effective filter shaker

Models available:

ATEX (for use in explosive atmospheres or/and with hazardous substances)

L-M-H filtration certification (for hazardous dust vacuuming)

SINGLE PHASE SERIES (1-3 KW)

COMPRESSED AIR SERIES



KM1



KMB2 KMB3



KM2 KM3



KC36



KC



KC2

Powerful, silent, robust industrial vacuums including high output self-cooled (by-pass) single-phase vacuum units.

KM1 is a **dry** single-phase vacuum cleaner ideal for vacuuming small quantities of light, fine and clogging dust.

KM2/KMB2 are **wet & dry** single-phase multipurpose vacuum cleaners for light, fine and clogging dust vacuuming. Thanks to the 90 liters bin version, they are suitable for liquid vacuuming as well.

High powerful KM3/KMB3 models permit time saving in heavy-duty cleaning tasks thanks to their extra power.

Very effective in the metal-work industry for vacuuming swarf and coolants.

Multi-purpose machines suitable for a lot of applications in any types of industry.

COMPRESSED AIR DRIVEN VACUUM CLEANERS

Applications:

- Heavy duty industrial cleaning operations;
- Sequential vacuuming on processing machines.

Robust and powerful: maintenance free pneumatic vacuum unit suitable where an electric unit cannot be used or for explosive areas.

Modular: automatic filter cleaning, absolute filtration and dust bag available as options.

Specific use: vacuuming of calamine and shot-blasting grit.

THREE PHASE INDUSTRIAL VACUUM CLEANERS FROM 2,2 TO 29 KW



K2 **K4S** **K5S**
K3 **K4P** **K5P**



KB2 **KB4S** **KB5S**
KB3 **KB4P** **KB5P**



K4P/56
K5P/56



KB4P/56
KB5P/56



K7 **K11S** **K13**
K9 **K11P** **K15**



KB5XP **KB7S**
KB7P



K7/78 **K11P/78** **K15/78**
K9/78 **K13/78** **K18/78**



K20S **K25S**
K20P **K25P**

Heavy-duty, silent, robust, effective: fitted with a soundproof, maintenance free, three phase side channel vacuum unit for continuous run use.

Filtration efficiency: versions /56 are equipped with a 3,5 m² filter area instead of 1,95 m² on the regular versions.

Modular: Upstream & downstream absolute filtration (HEPA), dust bin overflowing switch-off, electric filter shaker with push-button, automatic reverse jet cartridge filter system available as option.

Friendly use and maintenance: a high capacity dust collection bin with a quick and innovative release system ensures an easy vacuumed material emptying.

High filtering efficiency: a hygienic star filter with a large surface area ensures the maximum vacuuming efficiency for long periods of time when vacuuming very fine dust.

Effective filter cleaning by means of an ergonomic manual shaker.

User friendly: equipped with a robust frame, large diameter wheels and an easily releasable dust collection bin with wheels.

High capacity bin (50, 90 or 175 liters) with quick and innovative release system ensure easy vacuumed material emptying.

Compact, very stable and easy to handle.

Versatile: suitable for vacuuming fine dust, swarf, coolants, oil and water residue.

Design: balanced and elegant.

Effective solutions for heavy duty industrial vacuuming requirements.

Models available:

ATEX (for use in explosive atmospheres or/and with hazardous substances)

L-M-H filtration certification (for hazardous dust vacuuming)



Innovative quick release mechanism for bin emptying



Disposal bag vacuum balance system for dust collection directly into plastic bags (as option)

KOIL SERIES



KMB3.069



KOIL230



KMB3.070



KOIL330 KOIL340
KOIL355



Water repellent polyester filter cartridges fitted onto a KMB3.069 and a KMB3.070



KOIL440T KOIL455T
KOIL611T

INDUSTRIAL VACUUM CLEANERS FOR THE REMOVAL OF COOLANT, OIL AND SWARF FROM METAL WORK MACHINE TOOL SUMPS

Applications:

- Vacuuming of coolants, oil and swarf
- Macro separation of the liquids from swarf
- Return of filtered liquids for re-use, disposal, transfer or stockage.

Main features:

- 3 kW single phase
- Powerful from 3 to 13,2 kW three phase side channel vacuum units for continuous run.
- High reliability embedded expelling pump.
- Upstream safety filter.
- Automatic switch-off.
- Oil-proof polyurethane wheels with bearings and brakes.
- Basket for accessories.

Convenient: easy removal of the swarf basket due to a proper height position. Possibility to expel the filtered liquids during vacuuming.

Compact with a very good manoeuvrability.

Cleanable: the big size hatch located in the bottom of the tank permits an easy access for its cleaning operation.

SILVER LINE - FROM 0,4 TO 6,3 KW

Main applications:

- Blister, tablet press and capsule filling machines
- Vertical packing machines
- Laser technology and electronic

Heavy duty, silent, robust, effective: fitted with a three phase, sound-proof, maintenance free, side channel vacuum unit for continuous run.

High filtering efficiency: hygienic filters with large surface area ensure a maximum efficiency for long periods of time when vacuuming very fine dust. Filter cleaning by ergonomic manual shaker for an easy and effective maintenance.

Modular: configurable according to the specific requirements of the applications to be achieved.

Convenient use and maintenance: the quick and easy release system of the dust collection bin guarantees easy emptying.

Very compact and stable.

Versatile: suitable for vacuuming any kind of dust.

Effective solutions for process dedusting applications.

Options:

- AISI 304 or 316L stainless steel finishing
- Upstream or/and downstream absolute filtration (HEPA)
- Electric or pneumatic automatic filter cleaning
- Primary or/and absolute filters clogging monitoring systems
- Disposal bag vacuum balance system for dust collection directly into plastic bags
- Electric arrangement for remote on/off from the processing machine
- Exhaust air outlet arrangement for the connection to the building central ventilation system
- Bin overfilling sensor
- Single-phase execution
- Extraction arm with hood

Models available:

ATEX (for use in explosive atmospheres or/and with hazardous substances)

L-M-H filtration certification (for hazardous dust vacuuming)



KF10
KF16



KF22
KF30 KF30P



KF16.003
with extraction arm
with hood



KH0528 KH1028
KH1036 KH1636
KH2236 KH2246
KH3046 KH3046P



KV0528 KV1028
KV1036 KV1636
KV2246 KV3046
KV3046P



KR1046 KR1646
KR1656 KR2256
KR3056 KR4056
KR5056

ACCESSORIES (Diameters: 40, 50, 70 and 100 mm)

Reducers and hose fittings



Sleeves and hoses



Handgrips and extensions



Fixed and mobile floor nozzles



Rubber & silicone cones and suction nozzles



Zinc and stainless steel flat crevices



Rubber and silicone flat crevices and bent nozzles



Brushes



Other connectors, fittings and reductions



Probe and scraping nozzles



Painted preseparators



Stainless steel preseparators



For more details visit our website: www.kevac.eu

CENTRAL VACUUM CLEANING SYSTEM

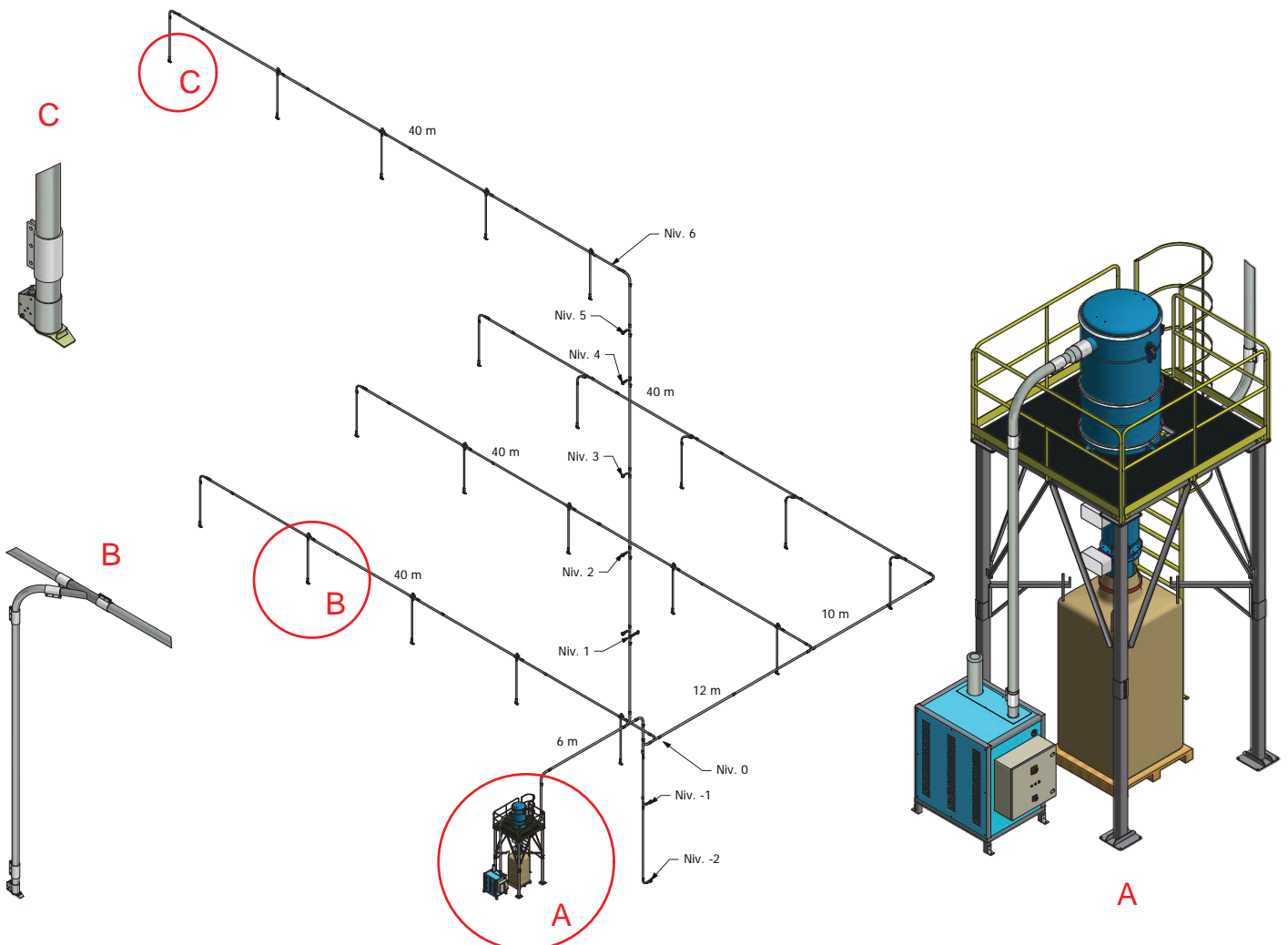

From its initial start up in 2007, Kevac projects itself as a modern and reliable challenger developing and manufacturing industrial vacuum equipment suitable for cleaning and processing operations.

The range of products includes a large number of models from 0,4 to 29 kW, available in various versions able to meet numerous market requirements, including models with ATEX and L-M-H filtration certification, as well as a full and comprehensive range of accessories and optional items.

Kevac's know-how and experience permit to offer customized solutions according to the end-users specific requirements and with the possibility to provide central vacuum cleaning and pneumatic conveying systems.

ATEX certificate for zones 21 (dust) and 1 (gas) through notified body INERIS.

ISO 9001 certification achieved in March 2014.

CERTIFICATIONS



FOCUS:

- Reliability
- Endurance
- Safety
- Hygiene
- Low acoustic level
- Compactness
- Power and performances optimization
- Ergonomics
- User friendly
- Stylish

OUR VISION

To become recognized globally
as a successful manufacturer of industrial vacuum systems
offering premium quality and service.

OUR STRENGTHS:

- Innovation
- Know how
- Background
- Customizing capability
- Flexibility
- Reactivity